

ROTOBLOC

TOOL CHANGEOVER SYSTEM FOR LEAN MANUFACTURING

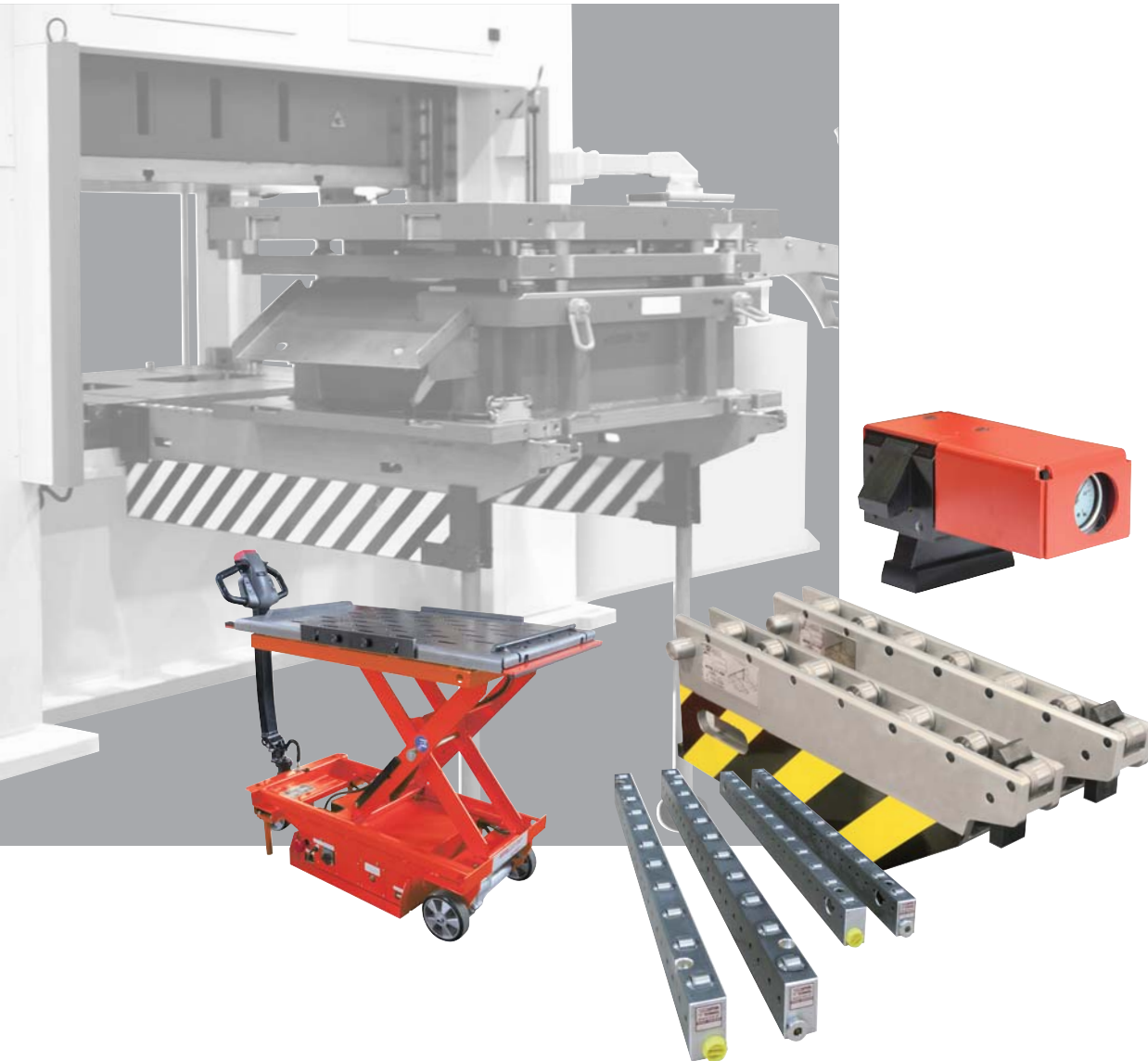

A SINGLE CONTACT TO DEAL WITH ALL YOUR TOOL NEEDS
www.rotobloc.com

COMPLETE RANGE OF QUICK DIE CHANGE SYSTEMS

Lean manufacturing solutions



Since 1985,
we offer solutions to reduce
tool changeover time.

SMED METHODS "SINGLE MINUTE EXCHANGE OF DIE"

Single minute exchange of die is one of the lean manufacturing tool concept enabling you to increase a process productivity. It's a quick and easy way to change production type.

Due to the reduction of the series changeover time, the size of the economic batch quantity is also reduced which in turn will make it possible to unblock funds spent in stocked components throughout the production chain.

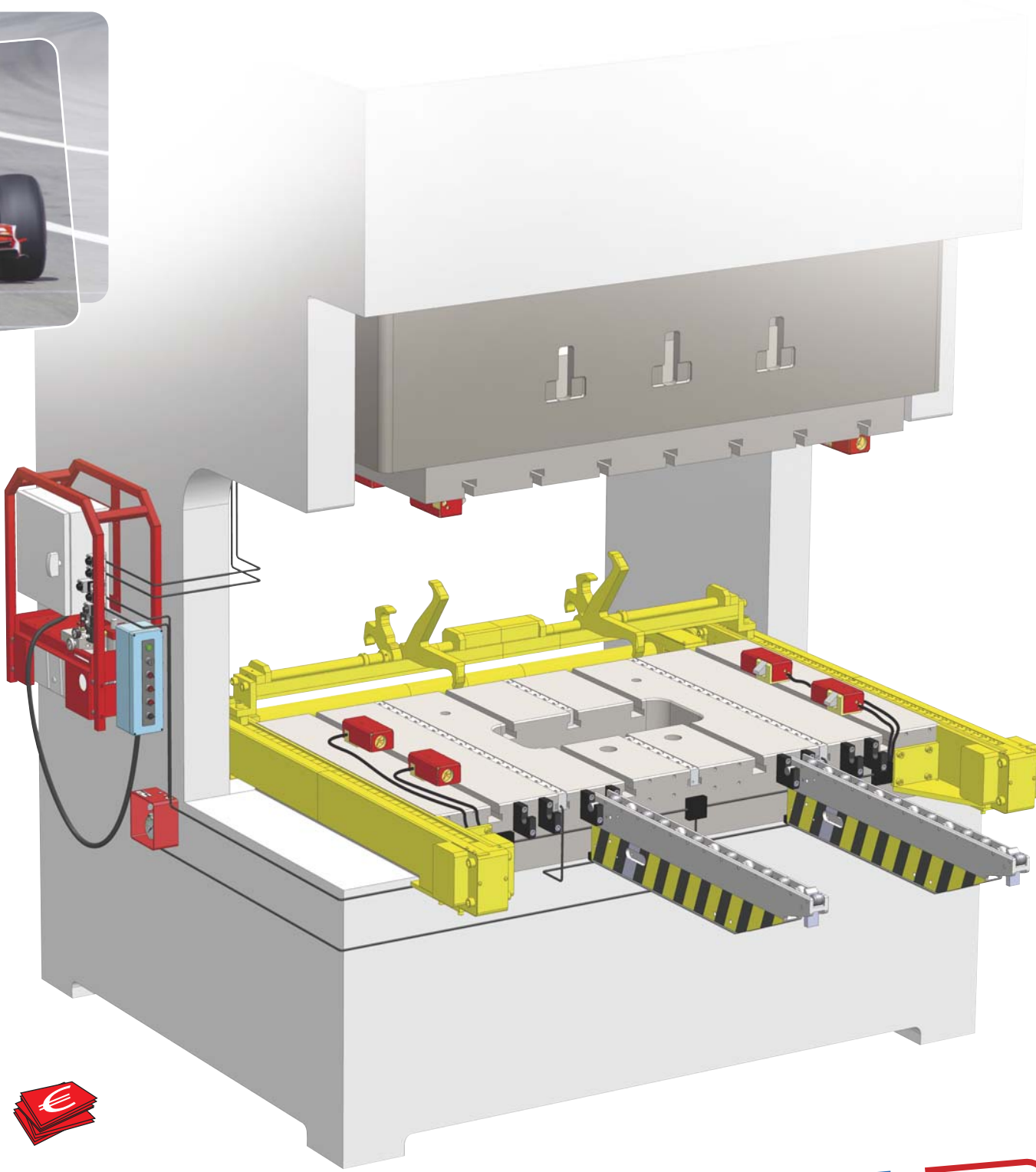
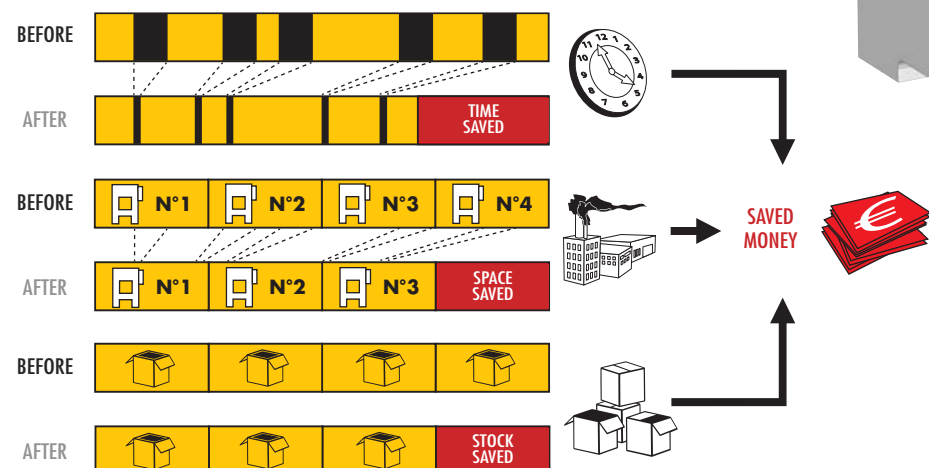

Reducing tool changeover time
and improving work conditions

CHANGE YOUR TOOLS SAFELY - p. 4



PULL AND PUSH YOUR TOOLS EASILY - p. 8



REDUCE TIME SPENT - p. 10



LOAD YOUR TOOLS EFFORTLESSLY - p. 14



**FRENCH
MANUFACTURER**

CHANGE YOUR TOOLS SAFELY

Bolster extensions : light series

Reducing the risk of workplace accidents

APPROPRIATE MEANS TO EASILY AND EFFORTLESSLY MANIPULATE LOADS WEIGHING SEVERAL TONS



Loading a tool directly on a press bed is very dangerous using a lift cart and simply impossible to do with a crane. The bolster extension makes it possible to safely load a tool either with a lift cart or a crane.

Besides making the operation safer, using an appropriate instrument will make you save a great amount of time. The bolster extensions are fitted out with rolls for heavy loads.

LIGHT AND STURDY



The extruded aluminium profiles is a perfect balance between strength and lightness. Gripping it manually is easy for the operator. Its sturdy conception allows it to support heavy loads.

FAST SET-UP

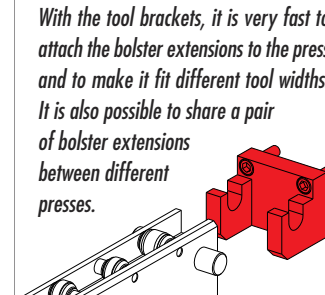

With the tool brackets, it is very fast to attach the bolster extensions to the press and to make it fit different tool widths. It is also possible to share a pair of bolster extensions between different presses.

SAFETY

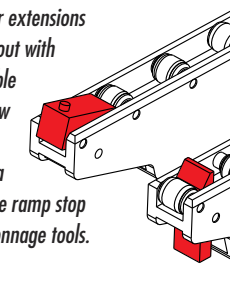

The bolster extensions are fitted out with a retractable stop for low tonnage tools and a progressive ramp stop for high tonnage tools.

STORAGE



DETACHABLE BOLSTER EXTENSIONS : TCF

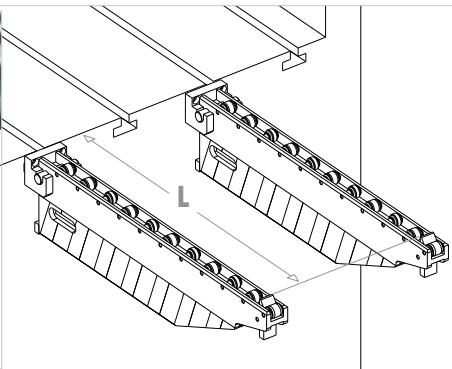

Thanks to the aluminum construction, the weight of the bolster extension makes it possible to handle it manually. Only the brackets are fixed to the press bed. The same pair of bolster extensions can be shared between the different presses of a workshop.

	L (mm) >	300	500	800	1000	1250
Maximum tool weight	500 kg	•	•	•		
	1 ton		•	•	•	•
	2 tons			•	•	•
	3 tons				•	•

ARTICULATED BOLSTER EXTENSION : TCAF

Compared with the rotating bolster, the articulated bolster has a second pivot point. This enables the bolster to be installed in cramped location as for instance soundproof cabins.

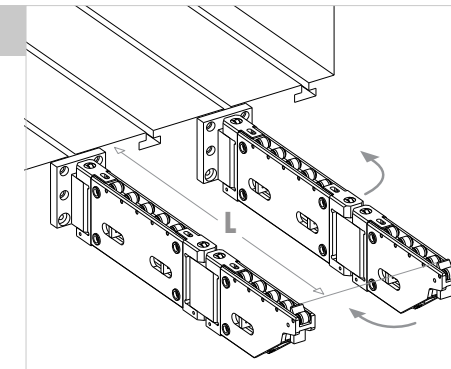

	L (mm) >	1000	1200
Maximal tool weight	500 kg	•	
	1 ton	•	
	2 tons	•	•

BOLSTER EXTENSIONS WITH SUPPORTING LEGS : TCP

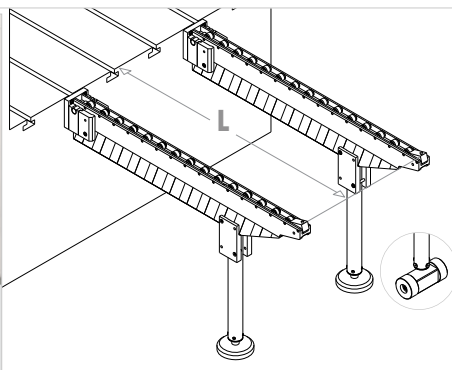

The bolster extension with supporting legs can also be moved and, thanks to its legs, it can support up to 6 tons. The basic version has a fixed leg. The optional leg with caster makes it easier to move the bolster extension around.

	L (mm) >	1000	1250	1600	2000	2500
Maximal tool weight	2 tons		•	•	•	
	4 tons	•	•	•	•	
	6 tons		•	•	•	•

ROTATING BOLSTER EXTENSIONS : TCRF

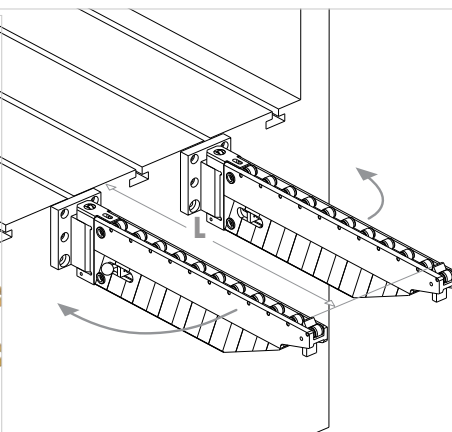

If the tools are very frequently changed, the rotating bolster extensions unfold themselves in an instant and automatically lock themselves in working position. Once the bolster extensions are folded against the press bed, the operator's work area is completely cleared. The rotating bolster extensions, are permanently fixed to the press bed.

	L (mm) >	400	600	900	1100
Maximal tool weight	500 kg	•	•	•	•
	1 ton		•	•	•
	2 tons			•	•
	3 tons				•

PUSH AND PULL UNIT : ILU

The push and pull unit was designed to save the operator from physical strain. The tool is transferred to the table bed in a controlled way and with a steady speed. The movement is managed by the operator himself. The push and pull unit is entirely integrated in the press bed. Only the pushing crossbar moves over the table but without touching it. The unit is compatible with existing bolster extensions and rails.

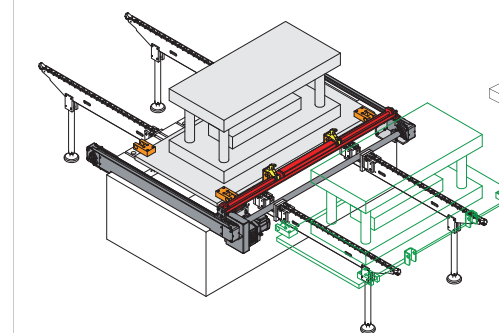

Double set-up to position tools as a background task.

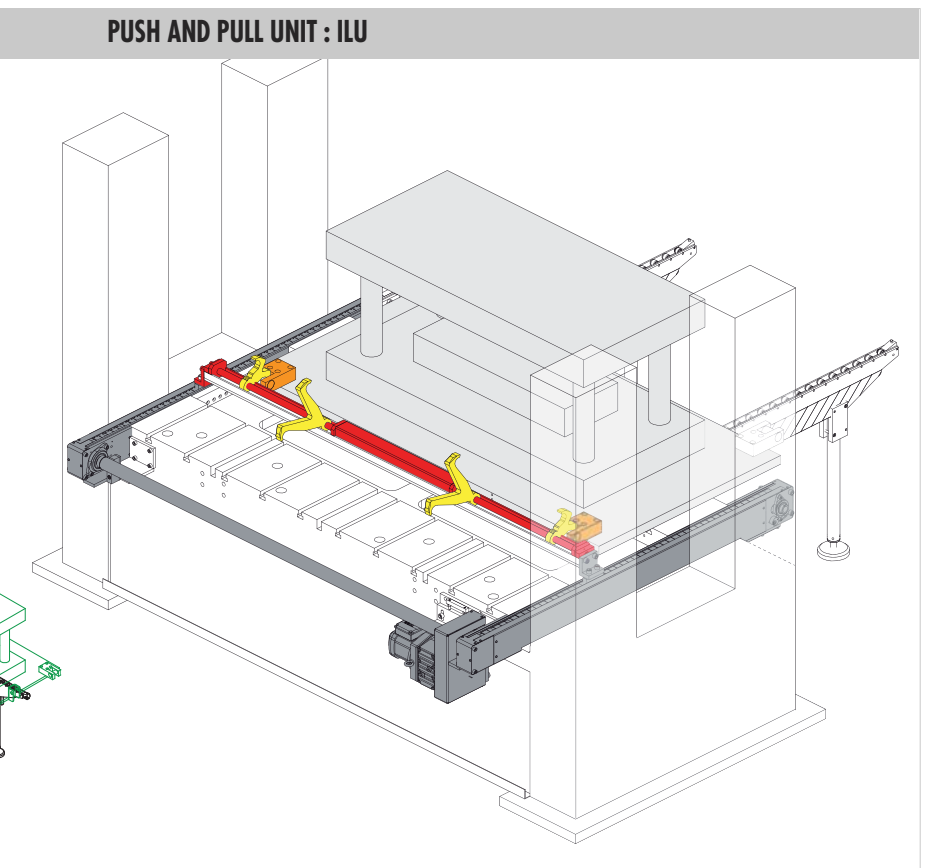

CHANGE YOUR TOOLS SAFELY

Bolster extension : heavy series

APPROPRIATE MEANS TO EASILY AND EFFORTLESSLY MANIPULATE LOADS WEIGHING UP TO 25 TONS



Always attached to the press, these bolster extensions will make you save a lot of time and will enable your operators to safely do their handling operations.

The studied technical layout enables these bolster extensions to be folded during production, which leaves a free access to the area for all your intervention (handling, checking) teams.

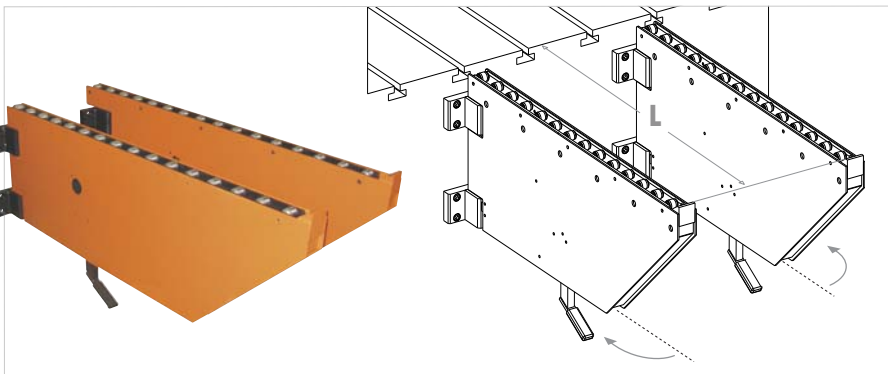

ROTATING BOLSTER EXTENSIONS : TCRSF/TCRDF

The articulation of the TCRSF/TCRDF bolster extensions makes it possible to fold them outward, contrarily to the TCRDF extension bolsters which are articulated asymmetrically and fold themselves on each other inward. In both cases, the bolster extensions are used only by pairs.

	L (mm) >	800	1000	1250	1500
TCRSF/TCRDF	4 tons	•	•	•	•
	6 tons	•	•	•	•

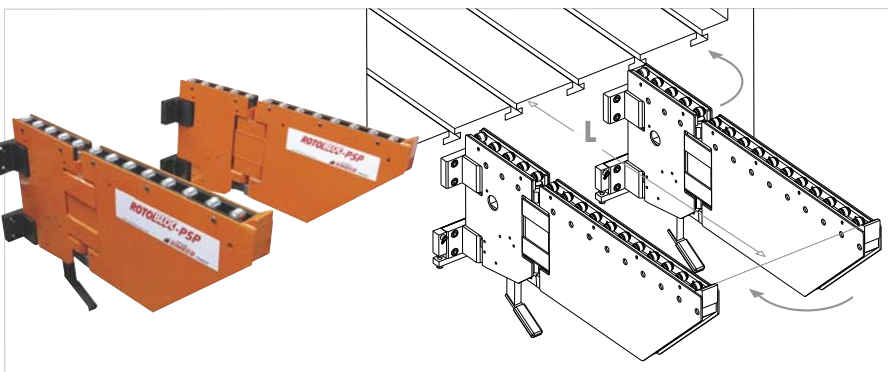

ROTATING BOLSTER EXTENSIONS : TCAF

These bolster extensions are used to quickly and safely change the tools on the press bed. They are permanently fixed to the front of the press bed with hinged brackets. They can adopt two set positions, the working position and the slide position, which allows complete access to the front of the press.

	L (mm) >	800	1000	1250	1500
TCAF	4 tons	•	•	•	•
	6 tons	•	•	•	•

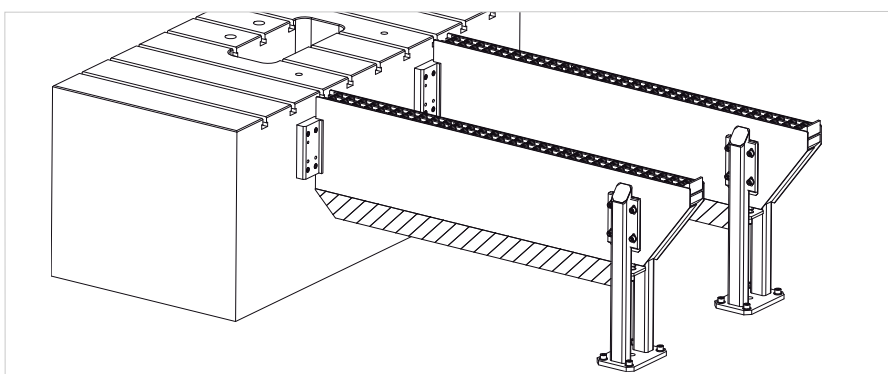

BOLSTER EXTENSIONS WITH SUPPORTING LEGS

Bolster extensions with supporting legs are particularly well suited for long tools. Thanks to their simple construction they are an affordable product. A detachable version is also available.

	L (mm) >	1250	1600	2000	2500
TCPP	10 tons	•	•	•	•
	16 tons		•	•	•

CUSTOMER APPLICATIONS

Our design office examines each one of your particular projects

BOLSTER EXTENSIONS WITH SUPPORTING LEGS FOR 12 TON TOOLS

Widely appreciated by cutting and stamping companies working in the automotive, metallic construction and building sectors.

Our bolster extensions with supporting legs are stationary or detachable with crane :

- Very sturdy construction
- Fitted out with two rows of rollers for the very heavy tools



MOTORIZED EXTENSION BOLSTER FOR 16 TON TOOLS

- Without mechanical connection
- Robust mechanical construction
- Synchronized hydraulic motorization
- Max. capacity : 16 tons
- Ref. : TCPPM



DETACHABLE MOTORIZED BOLSTER EXTENSIONS

Motorized bolster extensions are of a one-piece design integrating the bolster extensions to support the tool and a push and pull system.

The push and pull system can be activated a pneumatic motor or an hydraulic motor.

The same system can be adapted to different presses and to different tool sizes. The whole set can be moved with a crane or a forklift.



For 15 tons tools



For 8 tons tools

DETACHABLE LOADING TABLE

Customer set-up :

- For one 15 tons tool (4500x1800 mm)
- For two 8 tons tools (1200x1800 mm)
- For three tools.

Thanks to a hydraulic crossbar it is possible to transfer the tool effortlessly and progressively.

Different clamping systems are used depending upon the tools to load.



PUSH AND PULL YOUR TOOLS EFFORTLESSLY

Transfer elements for press bed with slots

BALL BEARING RAILS OR ROLLER RAILS



Moving a tool on a press bed can be a real hassle, but by integrating these segments to the press bed, the initial frictions will completely disappear.

Moving your tools will be totally safe, nearly effortless and faster than ever before.

You will also save time when cleaning it, as its one-piece construction prevents the shavings from piling up.

Reducing MSD (Musculoskeletal Disorders)

3 METER LONG IN A ONE-PIECE DESIGN

Our segments, made in extruded high strength aluminum alloy, are unfondable.

Because of their one piece design, the leaking risk is minimized. Its set-up is reliable and fast.

Once it is fitted out with its module, the segment is totally sealed and no shavings can enter it. Some customized segments can be made upon request.

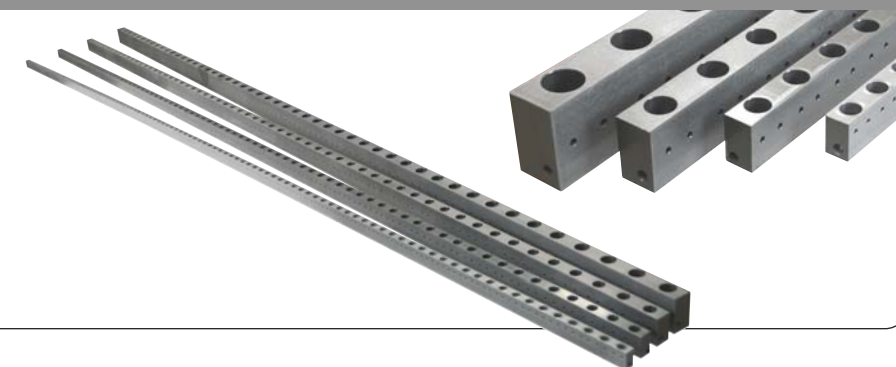

With rollers

Ball bearing

MODULE TYPES

STANDARD SLOTS

The 650 din standard established the dimension for the standard slots

Slot	a	b	c	h
18 mm	18	30	12	30
22 mm	22	37	16	38
28 mm	28	46	20	48
36 mm	36	56	25	61

CUSTOMIZED SLOTS

For further requests contact us and we will design a product meeting your specific needs

Slot	a mini	a maxi	h mini	h maxi
18 mm	18	22	29	38
22 mm	20	28	37	48
28 mm	26	36	44	61
36 mm	32	36	54	86

Press tool

Press table

HYDRAULIC AND MECHANICAL MODULES

TWO DESIGNS ARE AVAILABLE :

- The mechanical version is made of a spring which is compressed when the tool is clamped.
- The hydraulic version has modules which go up and down similarly to a single-acting hydraulic cylinder. The system is manually operated by an operator.

Hydraulic pack => page 13

MECHANICAL MODULE		HYDRAULIC MODULE		Model
Ball bearing	Rollers	Ball bearing	Rollers	
2000 kg	4000 kg	4000 kg	8000 kg	18
3000 kg	6000 kg	6000 kg	12.000 kg	22
3600 kg	7200 kg	7200 kg	14.400 kg	28
5000 kg	10.000 kg	10.000 kg	20.000 kg	36

Above example : Maximum capacity for a 3 m segment (minimum capacity of the range : 86 mm)
For lengths less than 3000 mm, please contact us !

ASSEMBLY TYPE

Standard stop : BS

Lateral stop : BL

In order to fit any kind of uses, two types of stops are available.

- BS "economic": held by one or more screw. The press bed has to be drilled and threaded.
- BL "fast assembly": held by a lateral tightening in the slot. No machining of the press bed is necessary.

CARTRIDGE FOR THE PRESS BED

Single module mounted in a body enabling it to be easily fitted in a press bed.

Available : smooth body or threaded body with balls or rollers

Body diameter (mm)	Version	Weight (kg)	
		Mechanical	Hydraulic
30	Ball	40	80
30	Rollers	80	160
35	Ball	60	125
35	Rollers	120	250

Threaded version

Smooth version

REDUCE TOOL CHANGEOVER TIME

Manual tightening clamping

Hydraulic and press clamping

THE EASIEST AND CHEAPEST SOLUTION ON THE MARKET

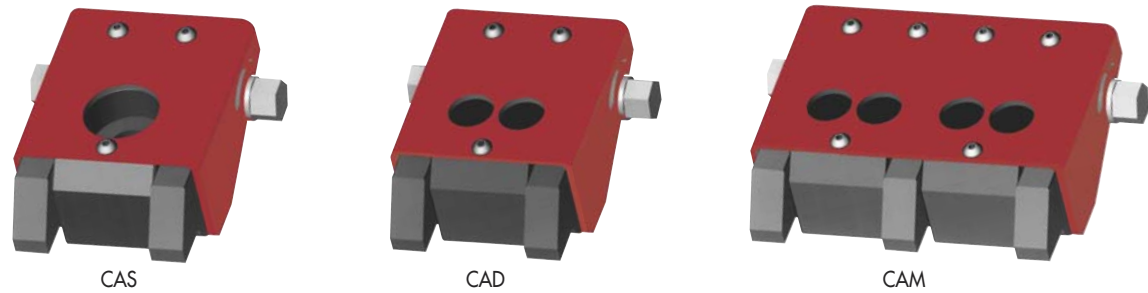

CAS

CAD

CAM

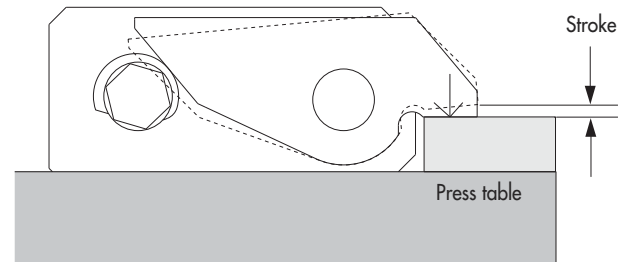

LEVER OPERATED MECHANICAL CLAMPS

The clamp operates thanks to lever mechanically operated by a self-locking cam. The clamps were specially designed to solve the very delicate issues occurring when clamping a tool to a press bed.

Tightening them with a t-shaped wrench makes it easy and effortless to reach a tightening torque going from 80 to 100 Nm that is to say a clamping force going from 12 to 25 kN.

The clamping force obtained from CA clamps is usually higher than the clamping force of conventional clamping systems which is generally comprised between 6.8 and 7.2 kN for a system with screws and nuts.

Model	Force (kN)	Stroke (mm)
CAS-0	16	5,8
CAS-1	18	3,1
CAS-2	20	3,4
CAS-3	24	4,2
CAD-2	20	3,4
CAD-3	24	4,2
CAM-1	18	3,1
CAM-2	20	3,4
CAM-3	24	4,2

CLAMPING SOLUTION WITHOUT USING A SPECIAL WRENCH/ ASSEMBLY JIGS

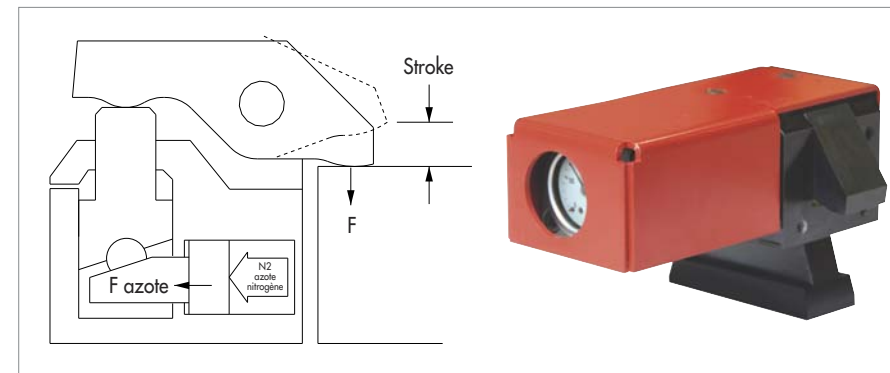

NITROGEN CLAMPING : NHLC

- Nitrogen clamp with hydraulic unclamping
- Fast clamping with a tool of standard thickness
- No pressure on the hose while the press is running
- The clamping strength generated by nitrogen is much steadier than the push of a mechanical spring.
- Controlling the nitrogen pressure with a manometer.

Hydraulic pack => page 13

Clamping strength (kN)	20	40	60	100
Stroke NHLC (mm)	5	6,4	8	9,5

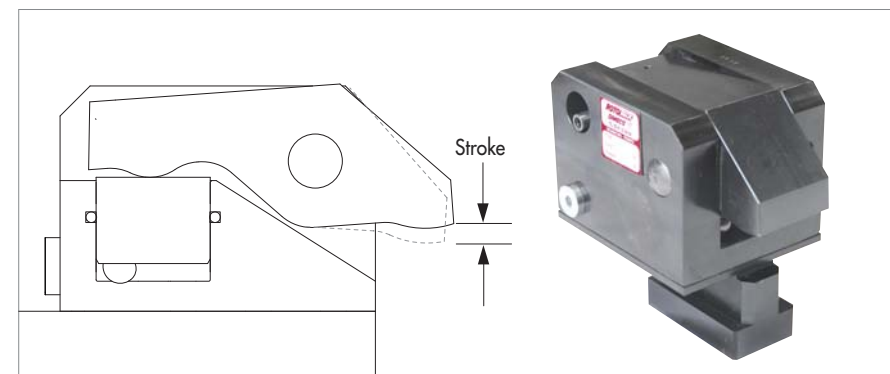

HYDRAULIC CLAMPING : HLC

- Simple and affordable : clamp with a hydraulic lever.
- The clamping power is drawn directly from the hydraulic pressure.

Hydraulic pack => page 13

Clamping strength (kN)	20	40	60	100
Stroke HLC (mm)	6	7	8	8

"NUT" CLAMPS WITH MANUAL TIGHTENING

The strength-multiplier nuts are clamps tightened by hand. They make it possible to obtain very high clamping forces without making any efforts.

Clamping strength (kN)	60	100	150	200
RMCA	•	•	•	•
RMCA - P	•	•	•	•
RMCA - B	•	•	•	•

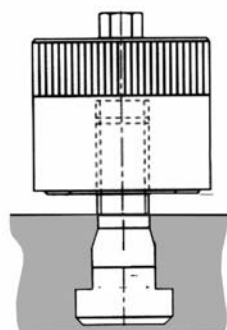

RMCA

RMCAB

RMCAP

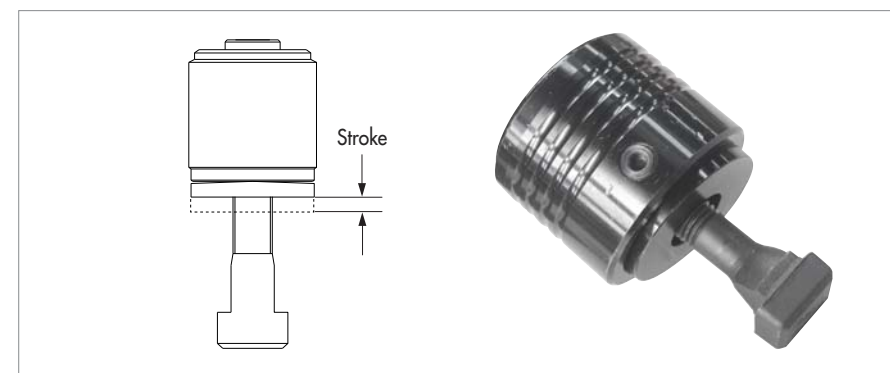

CLAMPING NUT : HTB

- Compact
- The clamping power is drawn directly from the hydraulic pressure.

Hydraulic pack => page 13

Clamping strength (kN)	28	44	72	102
Stroke HTB (mm)	6	6	6	6

REDUCE TOOL CHANGEOVER TIME

Magnetic clamping system

THE FASTEST AND MOST RELIABLE SOLUTION ON THE MARKET

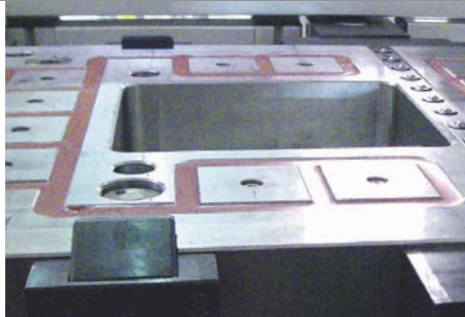
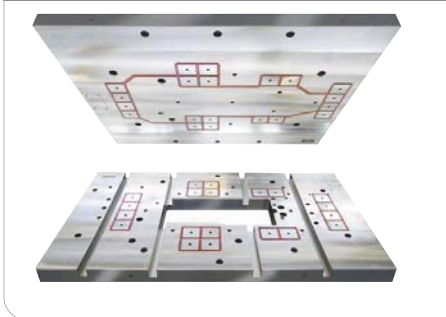

EFFICIENT AND EASY TO USE

SOLUTION BENEFITS :

- The tool is clamped in a matter of seconds just by pushing a button.
- No adjustments are needed to go from one tool size to another one. The magnetic poles adjust themselves according to the tool dimensions fitting the smallest and the biggest ones.
- No maintenance operations are needed as no parts are moving.

THE MOST RELIABLE SYSTEM ON THE MARKET :

- The clamping strength of each magnetic pole is monitored in real time.
- No risks to magnetize the active parts of the tool as the magnetic flux goes only up to 20 mm deep into the bottom of the die.
- No risk of unplanned unclamping. The clamping is electro-permanent. Electrical power is only needed during clamping and unclamping. Once the tool is clamped, the clamping is permanent.

SET-UP :

- Every plate is delivered with roller transfer rails.
- Every plate is designed according to the press dimensions, the press ram and the opening in the press bed.

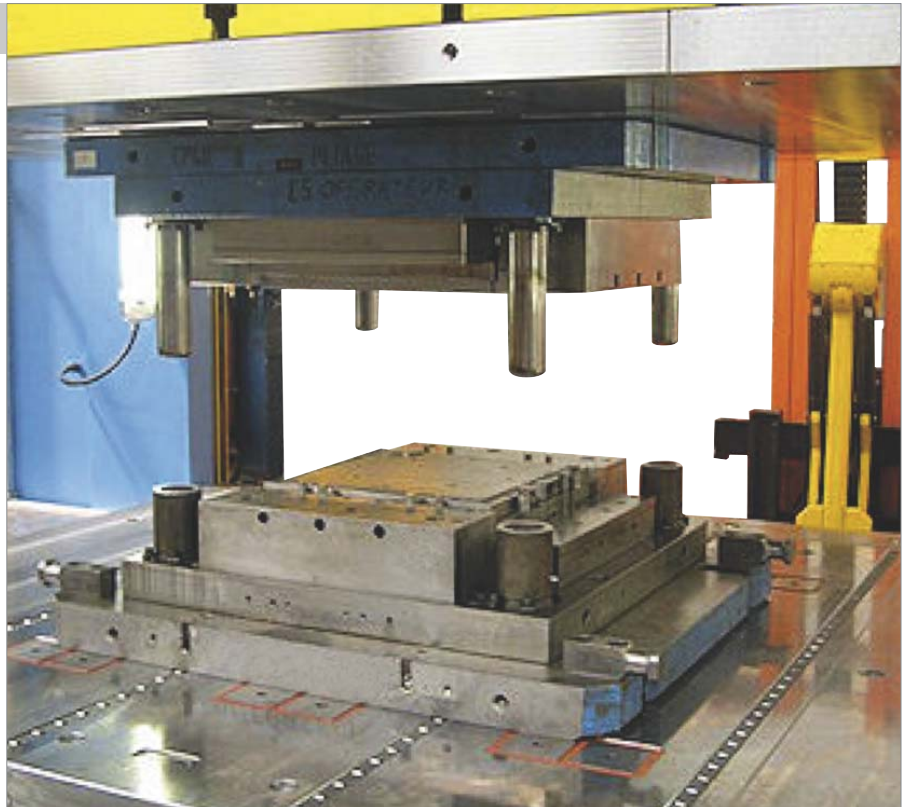

HYDRAULIC GENERATOR

for roller or ball segments and for gas or hydraulic clamps

MANUAL PUMP : HPMAN

The manual pump is used when there is no more pneumatic power.
It is both easy to set-up and to use.



AFFORDABLE AND SIMPLE GENERATOR

It generates hydraulic pressure of either 100 bars or 300 bars using a 6 bar compressed-air system.
Perfect for setting up both ball or roller rails and nitrogen clamping.

100 HPF and 300 HPF designs :

- Pressure : 100 or 300 bars
- Simple circuit with foot pedal (HPF)
- Double circuit with hand control (HPMD).



Operated by foot : HPF



Operated by hand : HPMS or HPMD

ELECTRICALLY OPERATED GENERATOR

Makes it possible to keep the hydraulic clamps power supply safe by setting up crossed clamping circuits.
Electrically operated generator from 1 to 5 circuits.
It is possible to integrate controls in a press control desk or a push button control.



HPE

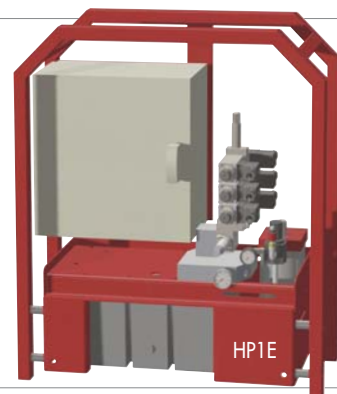

HP1E

ACCESSORIES : BDS

The security BDS block makes it possible to :

- Keep a circuit safe thanks to its pressure switch
- Stop the press in the event of an involuntary unclamping
- To prevent the press from running if the ball or roller rails are in a high position.

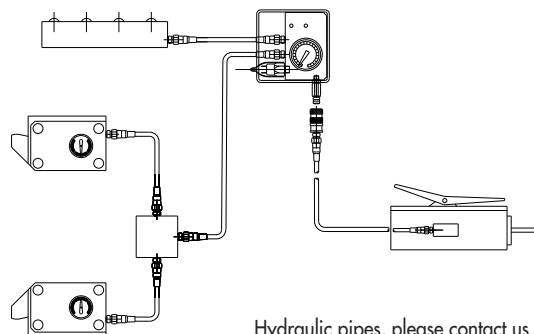

Hydraulic pipes, please contact us.

LOAD AND UNLOAD YOUR TOOLS EFFORTLESSLY

Tool handling for tools up to 1000 kg : carts and plates

TRANSFERRING YOUR TOOLS SAFELY AND EFFORTLESSLY



Erased balls: security



Activated beads: effortless translation

EASY TO USE :

- The lifting balls simply move up and down by the means of a manual handle
- Effortless loading : when loading the tool, it slides on the lifting balls.

SAFETY :

- When moving the tool around, the tool sits on the cover plate and the end stopper prevents it from sliding
- When sliding the tool in the press, it is important that the table is locked to the press table or to the rack.

ADAPTABLE PLATE

The plate by itself is available to be mounted on a table or on the forks of a lift cart.

The AQBFB reference is to put up the plate on a forklift while the AQBTA is for a table.

LIFTING OF THE BALLS/ROLLERS :

- Up to 1 ton model : manual lever
 - Up to 2 tons model : hydraulic cylinder.
- This model requires a hydraulic pack.

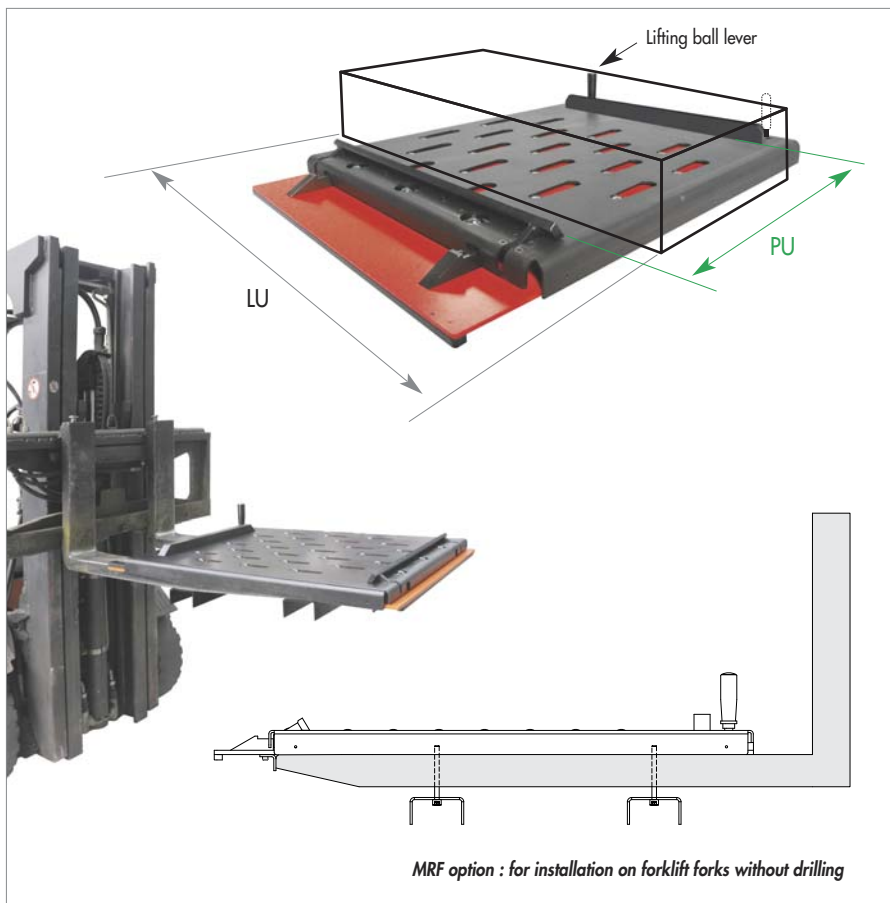

MRF option : for installation on forklift forks without drilling

	Model	kg	PU (mm)	LU (mm)
Ball	AQBTA	1000	410	850 / 900 / 1000
	AQBFB	1000	560	850 / 900 / 1000
	AQBFB	1000	710	850 / 900 / 1000
	AQBFB	1000	1000	1000
	AQBFBH	1000	550	1250
	AQBFBH	1000	650	1250
Rollers	AQBFBH	1000	800	1250
	AQRFH	2000	550	1250
	AQRFH	2000	650	1250
	AQRFH	2000	800	1250

MANUALLY OPERATED CARTS - LIFT

The Liftmatics are devices to transfer and lift tools manually, either thanks to a hydraulic pump operated with a pedal, either with a hydraulic pump operated by hand.

Two designs : 400 kg and 900 kg.

Electrical lifting table are available as an option.



LOAD AND UNLOAD YOUR TOOLS EFFORTLESSLY

Electrical Liftmatic

ELECTRICAL LIFTMATIC - LIFT E09 1000-1000

- Electric powered truck specifically designed for tool handling
- Retractable ball plate for easy and safe Quick Die Change
- Hydraulically powered up and down for effortless process

TRUCK SPECIFICATIONS

Plate height	Mini : 135 mm
LIFT E09 - H1650	Maxi : 1650 mm
LIFT E09 - H1950	Maxi : 1950 mm
1 Width of the truck	800 mm
2 Length of the truck	1800 mm
Driver	Pedestrian
Battery loader	Integrated EU 220V plug
3 Length of the leg	1005 mm (standard)
Thickness of the leg	80 mm
Roundabout	1100 mm

PLATE SPECIFICATIONS

Tool PU maxi	1000 mm
Tool LU maxi with side endstop	670 mm
LU maxi without side endstop	1000 mm
Tool maxi weight	900 kg

During tool transfer on press or storage, truck plate must be attached to the press/storage with connection part.

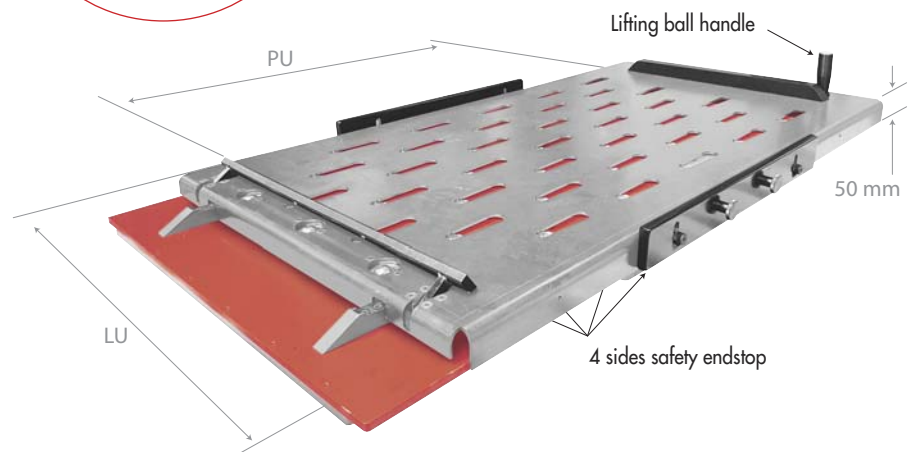
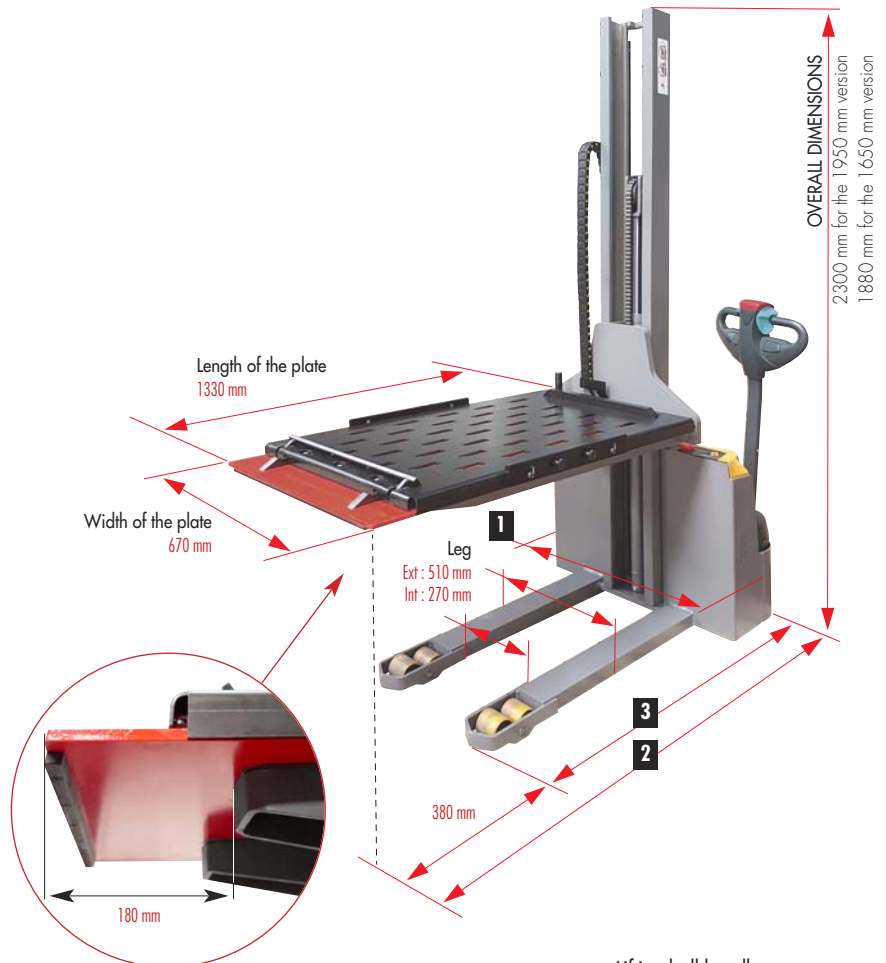
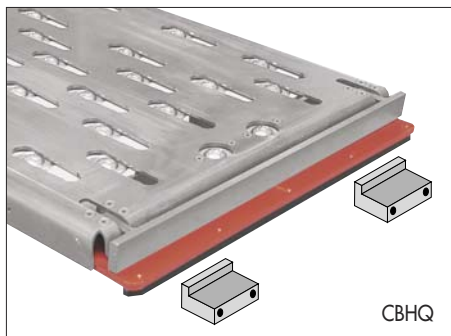

TRANSFERRING YOUR TOOLS SAFELY AND EFFORTLESSLY

EASY TO USE :

- The lifting balls simply move up and down by the means of a manual handle
- Effortless loading : when loading the tool, it slides on the lifting balls.

SAFETY :

- When moving the tool around, the tool sits on the cover plate and the end stopper prevents it from sliding
- When sliding the tool in the press, it is important that the table is locked to the press table or to the rack.



Retracted balls : safety



Activated balls : effortless translation

LOAD AND UNLOAD YOUR TOOLS EFFORTLESSLY

Tables

ELECTRICALLY POWERED TABLE

The plate has a sturdy metal construction with a small turning radius. Its small size and its electrical engine enable you to easily move it around the pathways of your production sites.

Easy to use thanks to its hydraulic lifting and lowering system. Moving the plate is only possible if the balls are withdrawn.

Maximum tool dimensions : 1000 x 1000 mm

Reference	Plate model	balls	flush	weight
Mult EF95	single chisel lifting action		•	950 kg
Mult EDF60	double chisel lifting action		•	600 kg
Mult EB90	single chisel lifting action	•		900 kg
Mult EDB55	double chisel lifting action	•		550 kg

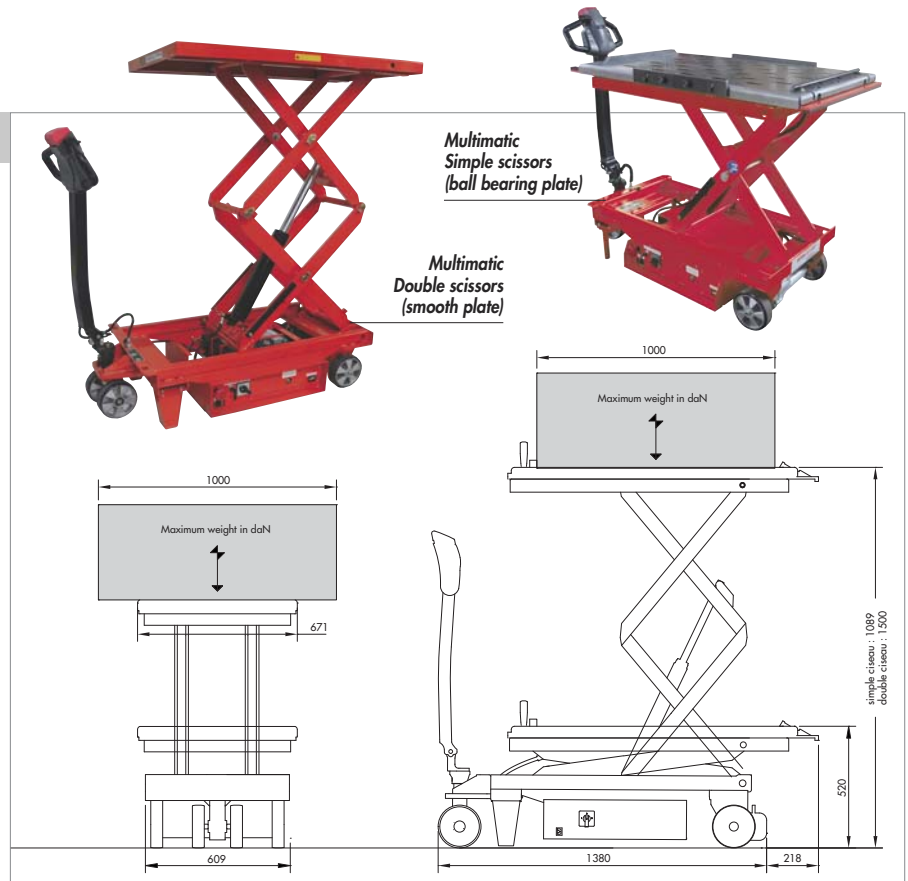

MANUALLY OPERATED TABLE

The most convenient solution for your operator to move a tool from the press bed to the storage/workbench or from one press to another one.

- The transfer is manually operated
- A hydraulic pump operated by hand enables the lifting
- Tools are loaded and unloaded through the front
- Perfect for carrying small tools
- It is completely safe both for the operator and for the loaded material
- Tare weight 280 kg.

Reference	PU (mm)	LU (mm)	Ball bearing plate
Mult F10	1000	900	NO*
Mult B10	560	900	YES

* smooth plate

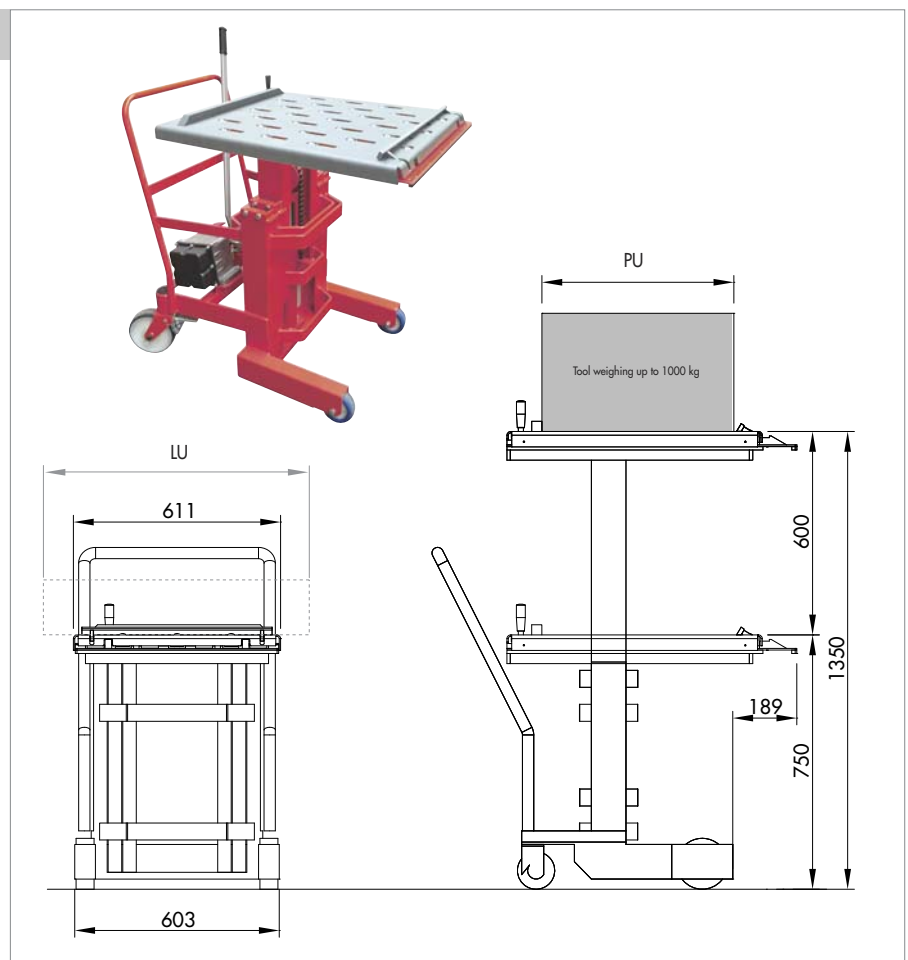

LOAD AND UNLOAD YOUR TOOLS EFFORTLESSLY

Tool handling for tools up to 2000 kg - TPI LIFTMATIC

DIE LOADING TABLE WITH PUSH-PULL SYSTEM FOR STANDARD FORKLIFT AND STACKER

The Push-pull system is powered by a hydraulic motor located inside the table. It is fitted out with hooks to grab the tools.

Easy adjustment and clamping of the hooks position. 2 long hooks are used for the positioning of dies up to 350 mm long, into the press bolster.

2 short hooks are used for deeper tools. A sensor located in the table detects its correct positioning, in front of a press bolster or a storage rack.

When in position, this sensor will allow the movement of the push-pull device. A second sensor will detect the push-pull back position, so the cart is allowed to move away.

This table can be easily assembled (or dismantled) on your standard forklift, thanks to quick connections (mechanical, hydraulic and electrical).

A vat located below the table collects slugs and oil. The top of the table is covered with a sliding plate.

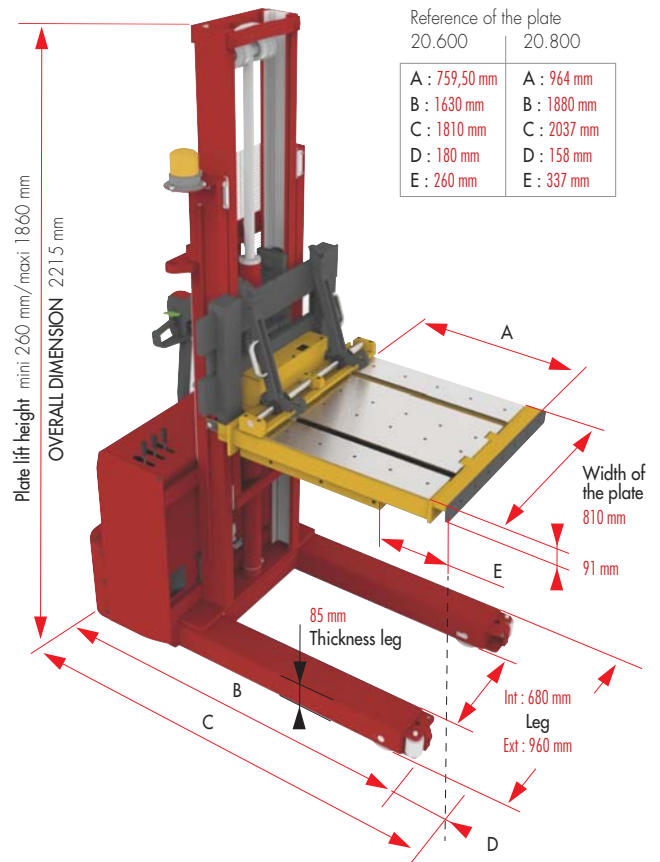

Reference of the plate	
20.600	20.800
A : 759,50 mm	A : 964 mm
B : 1630 mm	B : 1880 mm
C : 1810 mm	C : 2037 mm
D : 180 mm	D : 158 mm
E : 260 mm	E : 337 mm

TPI PLATE FEATURES

	Reference plate	20.600	20.800
Tool maxi dimensions	Weight (kg)	2000	2000
	PU (mm)	600	800
	LU (mm)	1400	1400
	Plate LU (mm)	820	820

LIFTMATIC TPI FEATURES

Ref. Liftmatic TPI	Tool maxi		
	Weight (kg)	PU (mm)	LU (mm)
10.600	1000	600	1400
10.800	1000	800	1400
20.600	2000	600	1400
20.800	2000	800	1400

Note :

- Overall plate 820 mm
- Mini lower position 265 mm
- Maxi higher position 1600 mm

TOOL HOOK :

Tool hook must be set-up on each tool (sold separately).

PLATE ATTACHMENT :

Press table and storage rack must be fitted out with pair of plate attachment (sold separately).

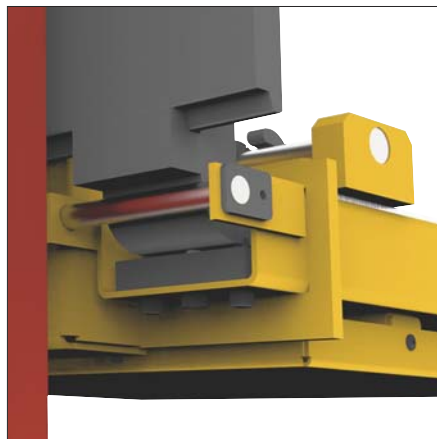
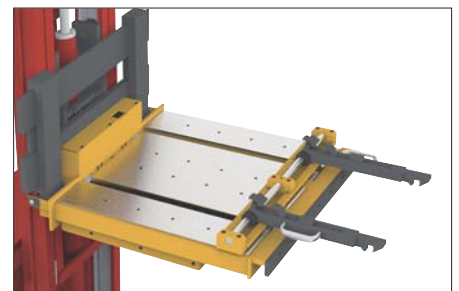
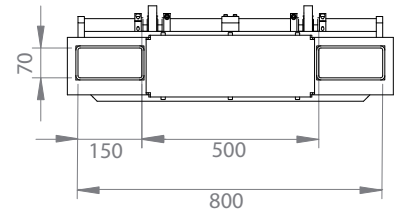
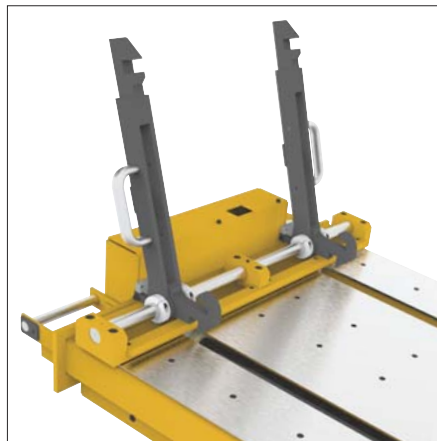
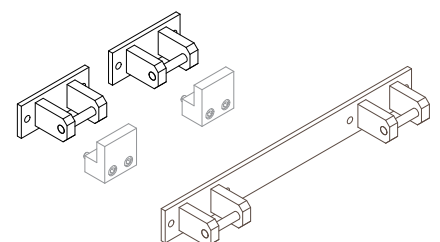

Plate locking device on forklift forks



Tool hook - Plate attachment

APPLICATIONS

Cryla - SKF - A.Raymond - Bosal - Caillau

SOLUTION FOR TOOL CHANGE WITHOUT HANDLING EQUIPMENT

- Capacity of two 900 kg tools
- Moving onto rolls or balls
- Tools secured in position
- Moveable table
- Production change time of 2 min 30 seconds
- Table attached to the press.



Advantages of this solution :

- Time saver, tools availability
- No more waiting time of handling equipment in order to change production.

IDEAL SOLUTION FOR TOOL CHANGE WITHIN LIMITED SPACE

- Manual Liftmatic, electrically driven upward and downward
- Flat surface
- 400 kg capacity
- Compact design for easy travel between presses
- Retractable and moveable side safety.



SPECIAL PLATE FOR FORKLIFT

- Special plate AQBFM* to set-up on forks
- Capacity 1000 kg
- Very easy manual moving of the tool with balls in upper position
- Secure use of the handling equipment with balls in lower position.

Additional safety :

- Sensor preventing handling equipment to move when balls are in upper position
- Side safety removable and moveable for smaller tools
- Fixed side safety for larger tools
- Integrated dripping oil collection tray.

The tool can be safely moved from the racking to the press and vice versa with the balls in lower position.

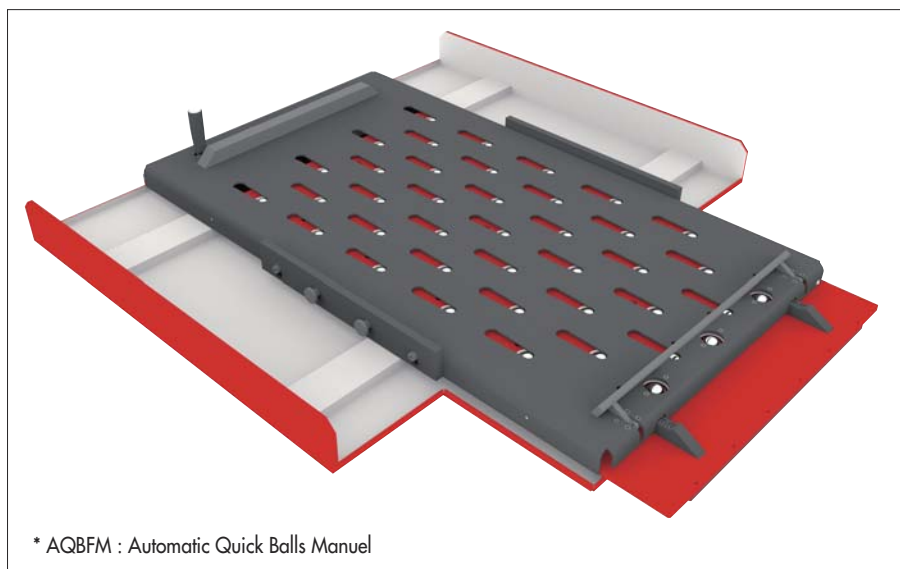

* AQBFM : Automatic Quick Balls Manuel

ELECTRICAL MULTIMATIC 2 TOOLS

- Changing a tool-simplicity itself !
- Rotating plate table, with retractable rollers.
- Minimum footprint.
- Maximum manoeuvrability.

TECHNICAL DATA : TOOL

Maximum weight	2 x 400 kg
Maximum width/depth	1000 x 575 mm

TECHNICAL DATA : TRUCK

Reference	MULTIMATIC E2x400R
Operation	Pedestrian
Truck movement	Electric
Lowering Height	800 - 1400 mm
Plate rotation	180°

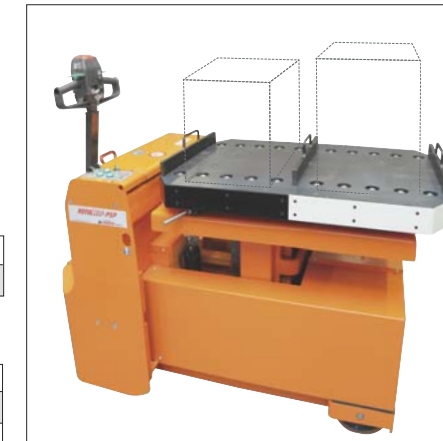

Plate for 2 tools with retractable rollers



180° rotating plate

ELECTRICAL MULTIMATIC WITH ADDITIONAL EXTENSION / PLATE TO GO OVER OBSTACLES

- 500 kg capacity
- Hydraulic plate moving when balls are activated
- Moving electrical forklift
- Retractable and moveable side safety.

TECHNICAL DATA : TRUCK

Reference	MULTIMATIC E500
Operation	Pedestrian
Truck movement	Electric
Lowering height	800 - 1400 mm
Plate extension	500 mm
PU x LU (mm)	650 x 710

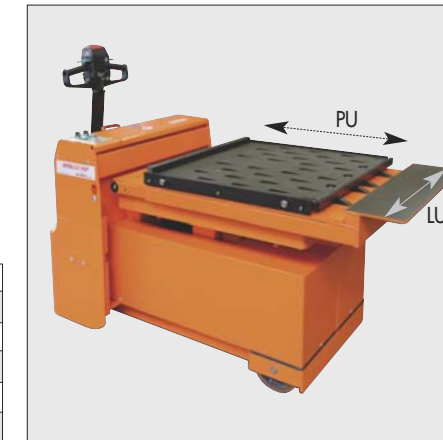
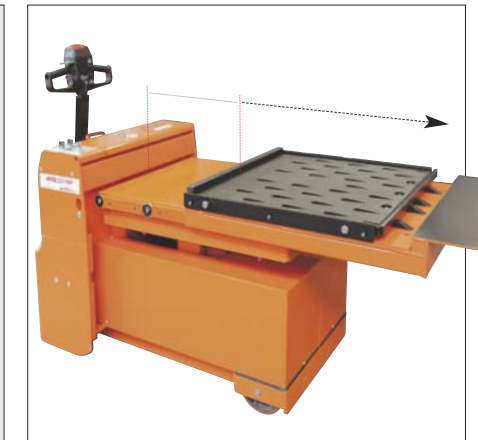

Plate with additional extension



500 mm extension

ELECTRICAL MULTIMATIC WITH PUSH-PULL UNIT

- Minimum footprint and with push-pull unit

TECHNICAL DATA : TOOL

Maximum weight	500 kg
Maximum width/depth	800 x 850 mm

TECHNICAL DATA : TRUCK

Reference	MULTIMATIC EP 1000
Driver	Pedestrian
Truck movement	Electric
Lowering Height	880 - 1480 mm
Push-pull tool loading	925 mm travel

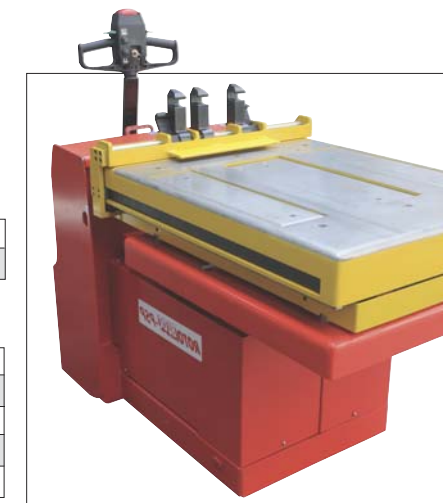

Compact construction for use in small workshops



DIE LIFTER AND CLAMPING DESCRIPTION

TOOL

	Smallest tool (mm)	Biggest tool (mm)
d		
w		
e		
k		
m		

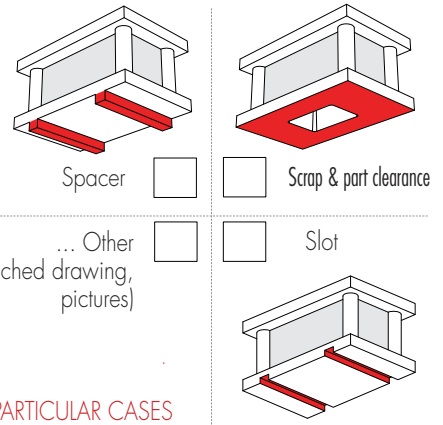
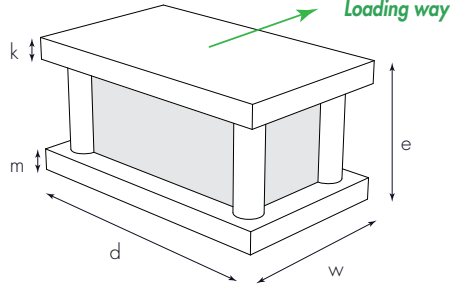

Tool plate material :

- Steel Aluminium
 Other :

Weight (kg)	min:	max:
Value if T°C > 70°C =		°C

Press table and ram

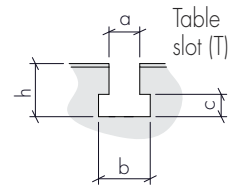
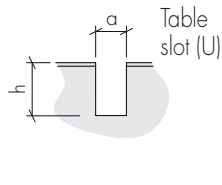
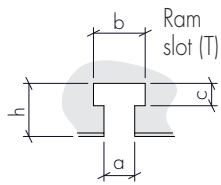
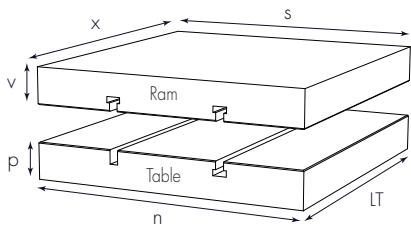

	mm
n	
LT	
p	
s	
x	
v	

Machining your slot upon request

	mm
a	
h	
b	
c	

Number of slots	
Spacing	

	mm
a	
h	

Number of slots	
Spacing	

	mm
a	
h	
b	
c	

Number of slots	
Spacing	

Press table

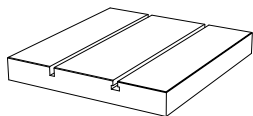

Single table

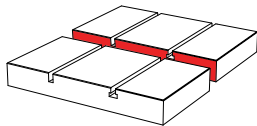

Double table

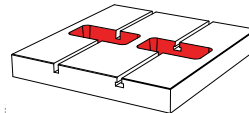
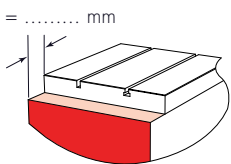

Table with holes

PARTICULAR CASES

... Other (attached drawing, pictures)

Position table / press basement



Smaller

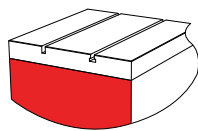

Flushing

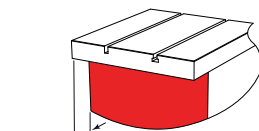

Larger

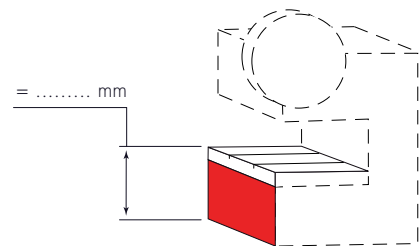

Press

"C-frame" press

Straight side press

Other :

Simple effect tonnage of the press	kN
------------------------------------	----

Several effects, other load => specify :