

Customer applications



ELECTRIC EQUIPMENT - RACKING & SHELVING - CONSTRUCTION & ROAD SAFETY
AUTOMOTIVE PRODUCTS - HOUSE APPLIANCES AND OFFICE FURNITURE - DISC CUTTING



DIMECO, all your press environment from one single source

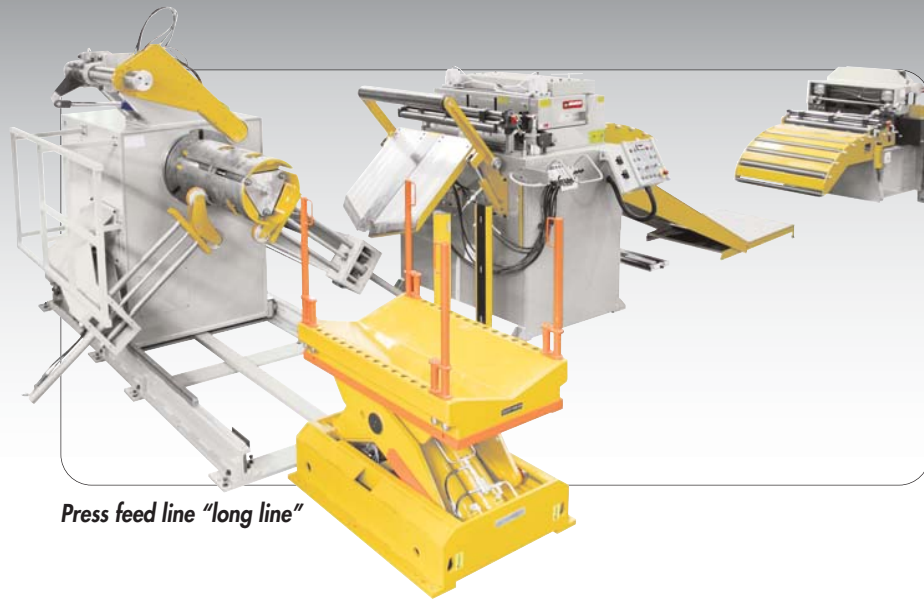

Press feed line "long line"



3 in 1 "best cost" solution



Press feed line "short line"

- Racks for coil storage
- Coil tilting units
- Coil cars
- Uncoilers
- Straighteners
- Corrective levellers
- Servo feeds
- Quick die change systems
- Tool loading car
- Racks for tool storage
- Die control units
- Press safety monitoring
- Stackers
- Pick & place - transfers

THE WORLD WIDEST RANGE OF MACHINES FOR SHEET METAL PRODUCTION SYSTEMS FROM COIL

- from 200 kg to 35 ton coils
- from 200 mm to 2000 mm wide strip
- from 0,2 to 9 mm material thickness
- tool weight up to 25 tons

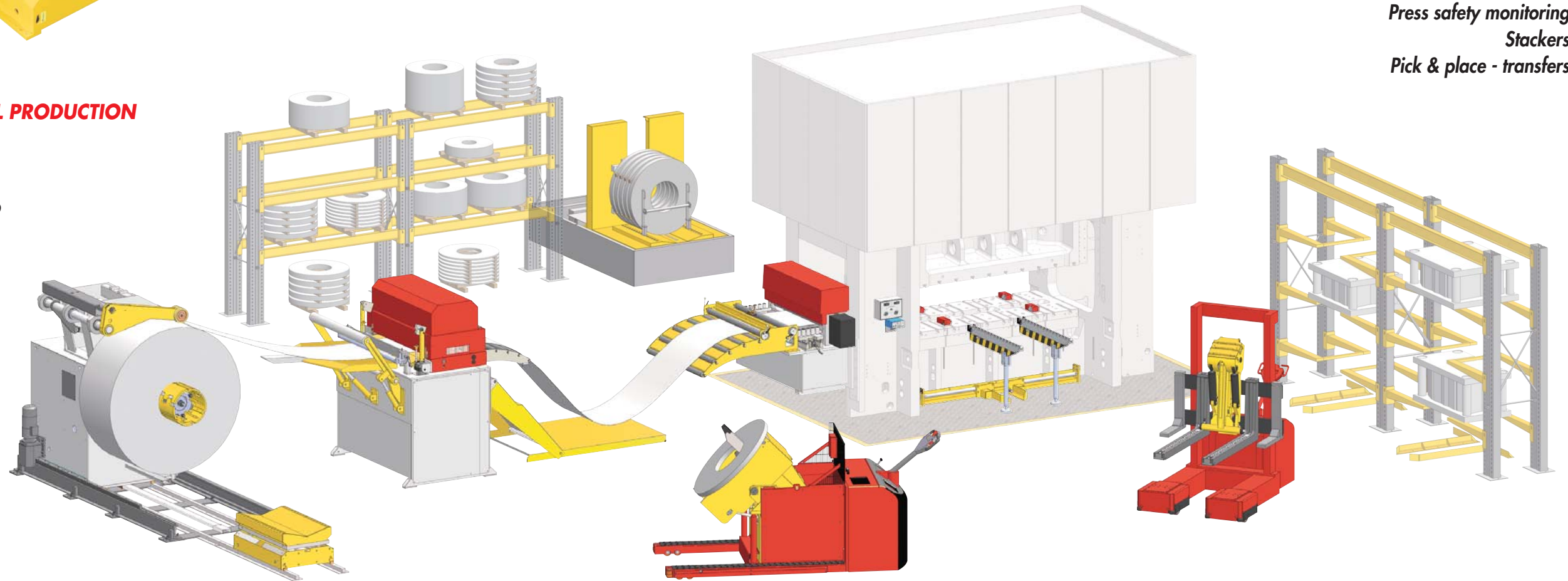

ENGINEERING
MANUFACTURING
INTEGRATION

DIMECO

TRAINING
INSTALLATION
SERVICE

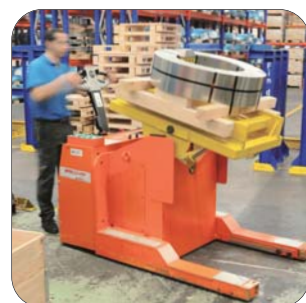

Coil handling : Quickcoil



Double uncoilers



ZIG-ZAG feeders



Tool handling : Quickblock

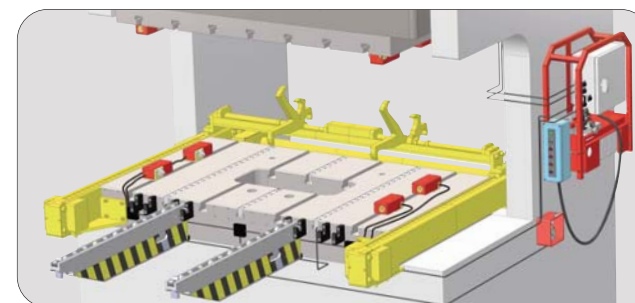

Press equipment for quick die change system

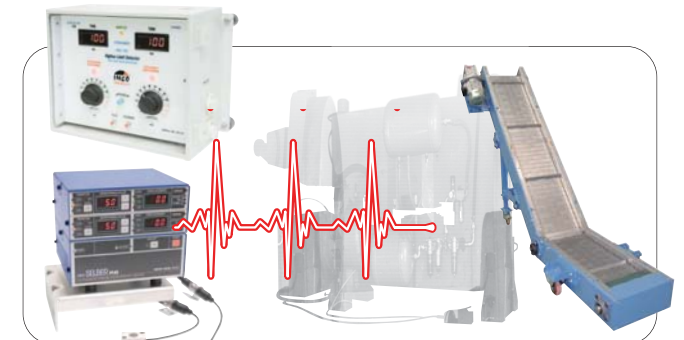

Press monitoring & accessories

Turn key system, all equipment from one single source **DIMECO**

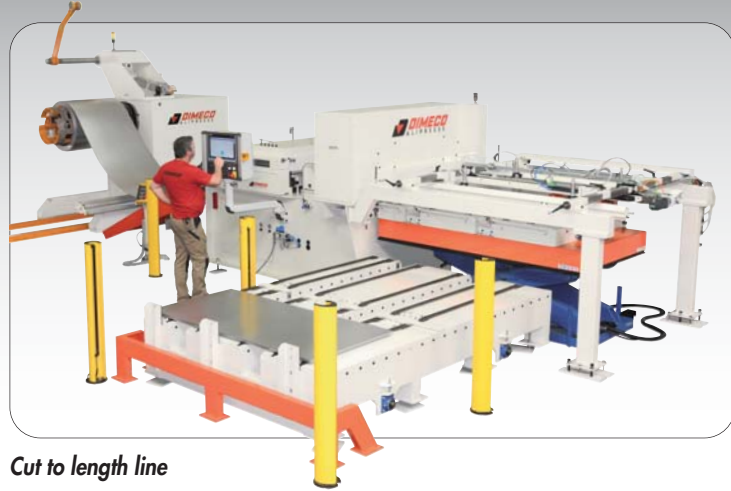

Cut to length line



Flexipress® Servo



Linapunch MC-E® Servo

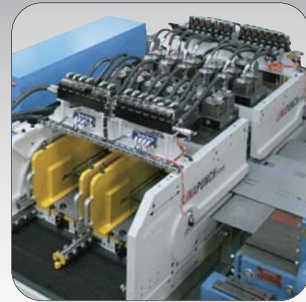

Linapunch® YT12 (hydraulic)

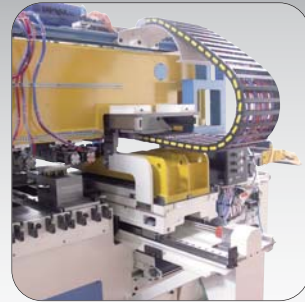

Flexipunch®



Punching and shearing

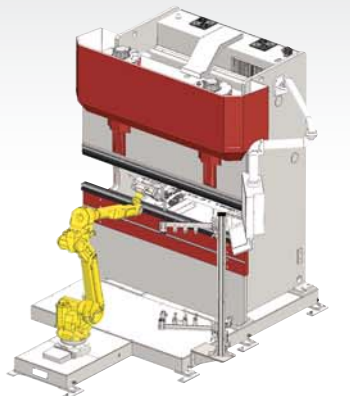

- Cut to length line (short & long design)
- Flexible punching machine (hydraulic & servo)
- Servo Flexipress®
- Lengthwise shearing systems
- Rollforming machine
 - cassette or adjustable design
 - profile cutting, start & stop or flying
- Automatic panel benders
- Robotic bending
- Robotic stacking
- Deburring
- Corner forming
- Automatic welding

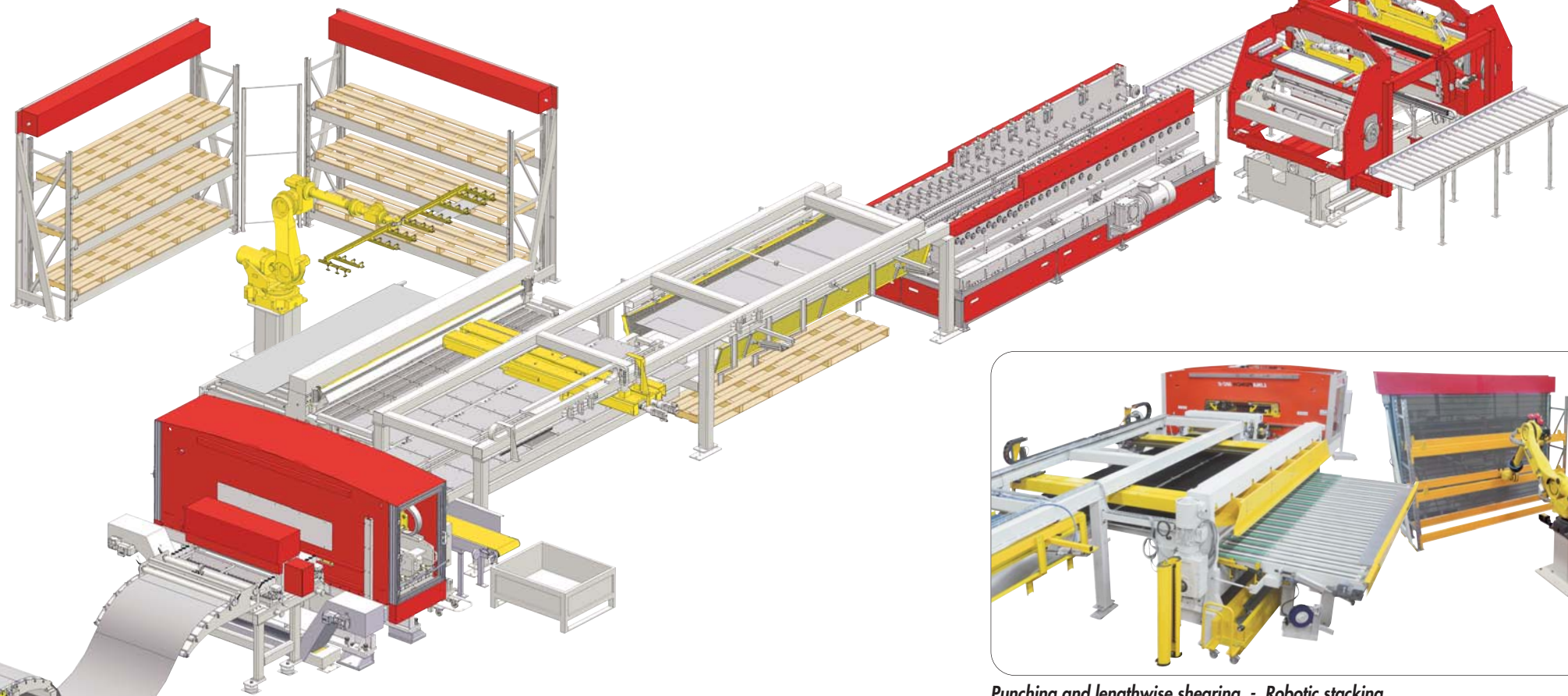

Punching and lengthwise shearing - Robotic stacking

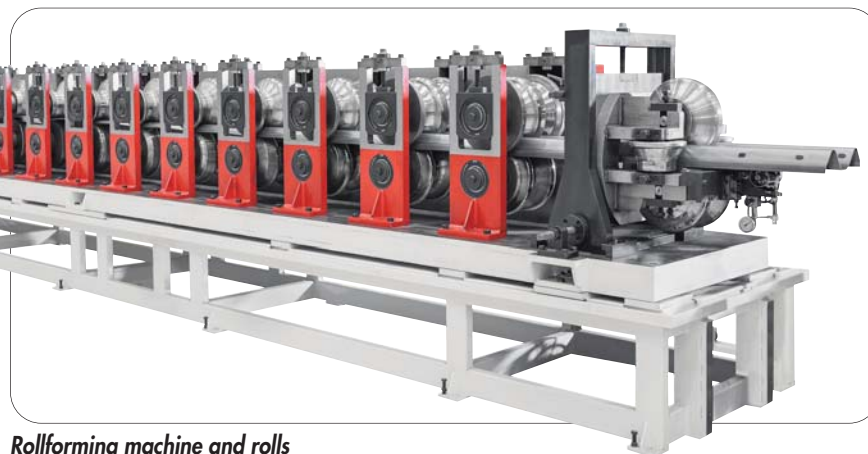
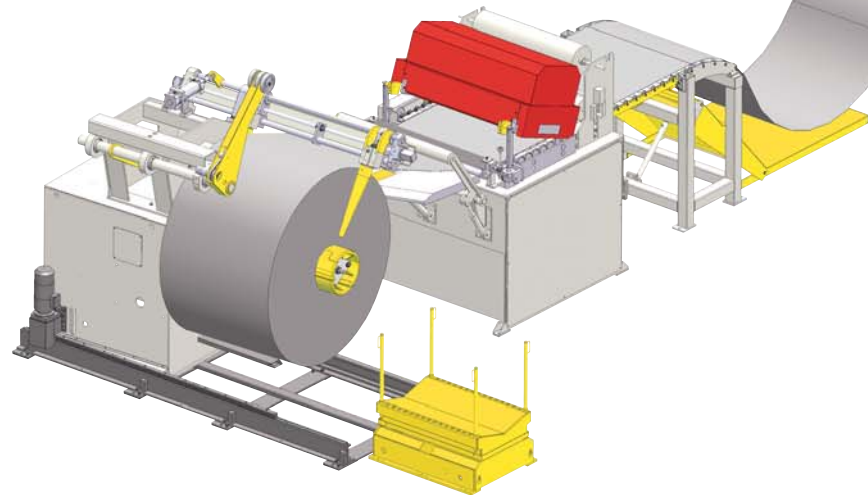

Rollforming machine and rolls



NC bending

Coil fed fiber laser

Linacut®



**The flexibility
of a fiber laser
combined with
the productivity
of working from coil**

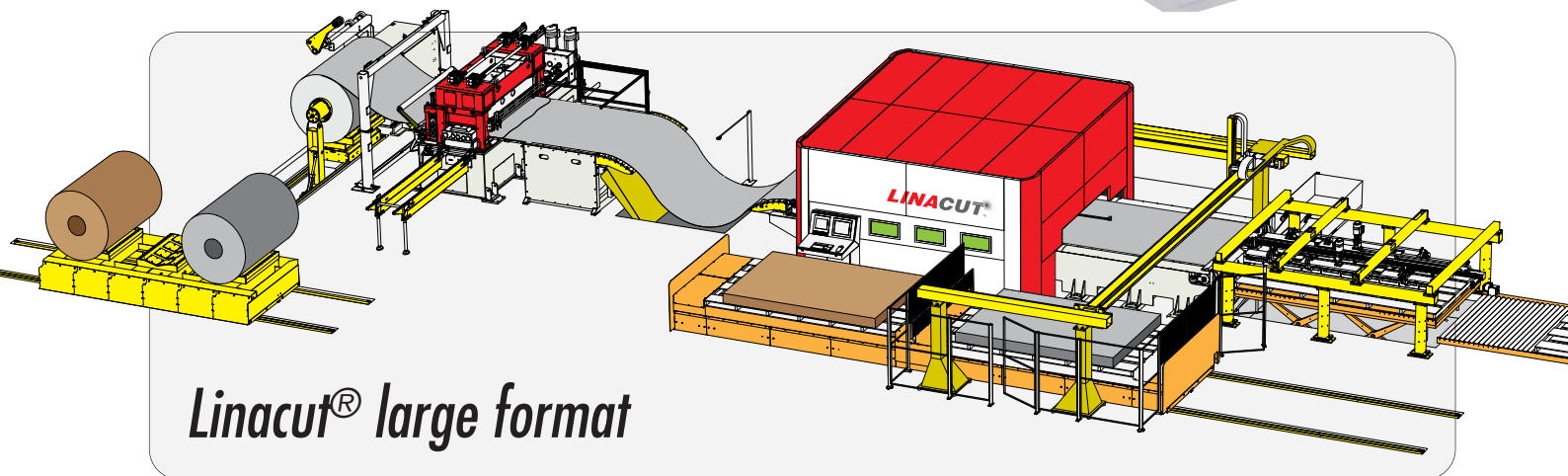

Linacut® large format

Linacut® small size



DIMECO Group

172 people - 3 production sites



2, rue du chêne - Z.I. la Louvière
25480 PIREY - FRANCE
Tél. +33 (0)3 81 48 38 00
Fax +33 (0)3 81 48 38 28

contact@dimeco.com
www.dimeco.com